

Meridium 1B1

EN Instructions for use (qualified personnel)	5
---	---

DE | INFORMATION

Zusätzlich zu der gedruckten Gebrauchsanweisung, sind auch weitere Sprachen auf CD beigelegt (siehe rückseitigen Umschlag). Auf Anfrage können Sie eine gedruckte Gebrauchsanweisung kostenlos in der jeweiligen Landessprache unter der unten angegebenen Anschrift bestellen.

EN | INFORMATION

In addition to the printed Instructions for Use, additional language versions are also included on CD (see back cover). You can order a printed version of the Instructions for Use at no charge in the respective national language at the address below.

FR | INFORMATION

Le mode d'emploi est disponible en d'autres langues sur CD en supplément de la version imprimée (voir au dos de la couverture). Vous pouvez commander gratuitement une version imprimée du mode d'emploi dans la langue de votre choix en envoyant votre demande à l'adresse indiquée ci-dessous.

ES | INFORMACIÓN

Aparte de las instrucciones de uso impresas, se incluye un CD con dichas instrucciones en otros idiomas (véase la solapa del dorso). Puede solicitar de forma gratuita unas instrucciones de uso impresas en el idioma de su país a la dirección que se indica más abajo.

IT | INFORMAZIONE

In aggiunta alle istruzioni per l'uso in formato cartaceo, il CD contiene le istruzioni anche in altre lingue (vedere il retro della copertina). Su richiesta, potete ordinare gratuitamente le istruzioni per l'uso in formato cartaceo nella relativa lingua del vostro Paese all'indirizzo di seguito riportato.

PT | INFORMAÇÃO

Adicionalmente ao manual de utilização impresso encontra-se incluído um CD com mais idiomas (consultar a contracapa). A pedido é possível encomendar gratuitamente um exemplar impresso do manual de utilização no respectivo idioma junto do endereço especificado.

NL | INFORMATIE

De gebruiksaanwijzing is behalve in gedrukte vorm ook in diverse andere talen bijgevoegd op cd (zie de achterzijde van de omslag). Een gedrukte gebruiksaanwijzing in de gewenste taal kunt u kosteloos bestellen op het hieronder vermelde adres.

SE | INFORMATION

Som komplement till den tryckta bruksanvisningen har dessutom ytterligare språk bifogats på CD (se baksidan av omslaget). Vid efterfrågan kan du utan kostnad beställa en tryckt bruksanvisning i det respektive språket under den angivna adressen.

DA | INFORMATION

Supplerende til brugsanvisningen på papir er der også vedlagt yderligere sprog på cd (se bagsiden af omslaget). På den oplyste adresse nedenfor kan du bestille en gratis brugsanvisning på papir på det pågældende sprog.

NO | INFORMASJOU

I tillegg til den trykte bruksanvisningen er flere språk vedlagt på CD (se på baksiden omslaget). Ved forespørsel kan du bestille en gratis trykt bruksanvisning i det gjeldende språket via adressen nedenfor.

FI | TIEDOT

Painetun käyttöohjeen lisäksi tarjoaa oheinen CD-levy käyttöön myös lisää kieliä (katso kansilehden takapuoli). Painettu käyttöohje kunkin maan omalla kielellä on pyynnöstä tilattavissa maksutta alla ilmoitetusta osoitteesta.

CZ | INFORMACE

Kromě této vytištěné verze návodu k použití jsou na přiloženém CD k dispozici také další jazykové verze překladu (viz zadní strana obalu). V případě požadavku si můžete na níže uvedené adrese zdarma objednat vytištěný návod k použití v příslušném jazyce.

PL | INFORMACJA

Dodatkowo do wydrukowanej instrukcji użytkowania dołączono na CD wersję w innych językach (patrz tył okładki). Na żądanie istnieje możliwość zamówienia bezpłatnie pod podanym poniżej adresem wydrukowanej instrukcji użytkowania w języku danego kraju.

SK | INFORMÁCIA

Dodatočne ku vytlačnému návodu na používanie sú na CD uložené aj ďalšie jazyky (pozri zadnú obálku). Na požiadanie si môžete bezplatne objednať vytlačný návod na používanie v príslušnom jazyku krajiny na dole uvedenej adrese.

HU | INFORMATION

A kinyomtatott használati utasítást kiegészíti a további nyelveket tartalmazó, mellékelt CD (ld. a hátlaapon lévő borítékot). Az alábbi címen, kérésre költségmentesen megrendelhet az adott ország nyelvén kinyomtatott használati utasítást.

HR | INFORMACIJA

Dodatno uz tiskane upute za uporabu priloženi su i drugi jezici na CD-u (vidi poledinu). Na upit možete na dolje navedenoj adresi besplatno naručiti tiskane upute za uporabu na dotičnom jeziku.

TR | INFORMATION

Basılmıř olan kullanım kılavuzuna ilave olarak CD'de daha fazla alternatif diller bulunmaktadır (bakınız zarfın arka yz). İstek zerine ilgili dilde basılmıř kullanım kılavuzunu ařađıda belirtilmiř olan adresten temin edebilirsiniz.

Ottobock Healthcare Products GmbH

BrehmstraÙe 16 | 1110 Wien | Austria

Service-admin.vienna@ottobock.com | Fax (+43-1) 526 79 85

Table of contents

EN

1	Foreword	7
2	Product description	7
2.1	Design	7
2.2	Function	7
2.3	Combination possibilities	8
3	Application	8
3.1	Indications for use	8
3.2	Area of application	8
3.3	Conditions of use	8
3.4	Service Life	9
3.5	Indications	9
3.6	Qualification	9
4	Safety	9
4.1	Explanation of warning symbols	9
4.2	Structure of the safety instructions	9
4.3	General safety instructions	9
4.4	Information on the Power Supply/Battery Charging	11
4.5	Battery charger information	12
4.6	Information on Alignment/Adjustment	12
4.7	Information on Proximity to Certain Areas	13
4.8	Information on Use	13
4.9	Notes on the safety modes	14
4.10	Information on the use of a mobile device with the cockpit app	15
5	Scope of Delivery and Accessories	15
6	Charging the battery	16
6.1	Connecting the power supply and battery charger	16
6.2	Charging the prosthesis battery	17
6.3	Display of the current charge level	17
7	Preparation for use	18
7.1	Applying/removing footshell	18
7.2	Alignment	18
7.2.1	Bench alignment in alignment apparatus	18
7.2.2	Static alignment optimisation	18
7.2.3	Dynamic alignment optimisation	18
7.2.4	Mounting cover plate/connecting plate/cover cap	19
7.2.4.1	Mounting the cover cap	19
7.2.4.2	Mounting the cover plate	19
7.2.4.3	Mounting the Protector connecting plate	19
7.2.4.4	Mounting the connecting plate for the cosmetic foam cover	19
8	Cockpit app	20
8.1	System Requirements	20
8.2	Initial connection between cockpit app and prosthesis	20
8.2.1	Starting the cockpit app for the first time	20
8.3	Control elements for cockpit app	21
8.3.1	Cockpit app navigation menu	22
8.4	Managing prostheses	22
9	Use	23
9.1	Setting the heel height	23
9.1.1	Setting heel height using motion pattern	23
9.1.2	Setting the heel height with the cockpit app	23
9.1.3	Setting heel height using remote control	24

9.2	Movement patterns in basic mode (mode 1)	24
9.2.1	Standing	24
9.2.2	Walking	24
9.2.3	Sitting down/sitting	25
9.2.4	Standing up	25
9.2.5	Walking up stairs	25
9.2.6	Walking down stairs	25
9.2.6.1	Stair function	25
9.2.7	Walking up a ramp	26
9.2.8	Walking down a ramp	26
9.2.9	Walking backwards	26
9.2.10	Standing on inclined surface	26
9.2.11	Kneeling	27
9.2.12	Relief function	27
9.3	MyModes	27
9.3.1	Switching MyModes with the cockpit app	27
9.3.2	Switching MyModes using motion patterns	28
9.3.3	Switching on ankle lock	28
9.3.4	Switching from a MyMode back to basic mode	29
9.4	Changing prosthesis settings	29
9.4.1	Changing the prosthesis setting using the cockpit app	30
9.4.2	Overview of adjustment parameters in basic mode	30
9.4.3	Overview of adjustment parameters in MyModes	31
9.5	Switching off the product	31
9.6	Turning Bluetooth on the prosthesis on/off	32
9.6.1	Switching Bluetooth off/on using the cockpit app	32
9.7	Querying the prosthesis status	32
9.7.1	Query status through cockpit app	32
9.7.2	Status display in the cockpit app	32
9.7.3	Status information on the display of the remote control (optional accessory)	32
10	Additional operating states (modes)	32
10.1	Empty battery mode	32
10.2	Mode for charging the prosthesis	33
10.3	Safety mode	33
10.4	Overheating mode	33
11	Cleaning	33
12	Maintenance	33
13	Disposal	33
14	Legal information	33
14.1	Liability	33
14.2	Trademarks	34
14.3	CE Conformity	34
14.4	Local Legal Information	34
15	Appendices	35
15.1	Symbols Used	35
15.1.1	Symbols on the product	35
15.1.2	Symbols on remote control	35
15.1.3	Symbols on the battery charger	36
15.2	Operating states/error signals	36
15.2.1	Signals for operating states	36
15.2.2	Warnings/error signals	37
15.2.3	Error messages while establishing a connection	38
15.2.4	Status signals	39
15.3	Technical data	39

1 Foreword

INFORMATION

Last update: 2016-01-25

- ▶ Please read this document carefully before using the product.
- ▶ Follow the safety instructions to avoid injuries and damage to the product.
- ▶ Instruct the user in the proper and safe use of the product.
- ▶ Please contact the manufacturer if you have questions about the product (e.g. regarding the start-up, use, maintenance, unexpected operating behaviour or circumstances). Contact information can be found on the back page.
- ▶ Please keep this document in a safe place.

From this point, the product "1B1 Meridium" shall be referred to simply as the product/component/prosthes-is/prosthetic foot.

These instructions for use provide you with important information on the use, adaptation and handling of the product.

2 Product description

2.1 Design

The product consists of the following components:

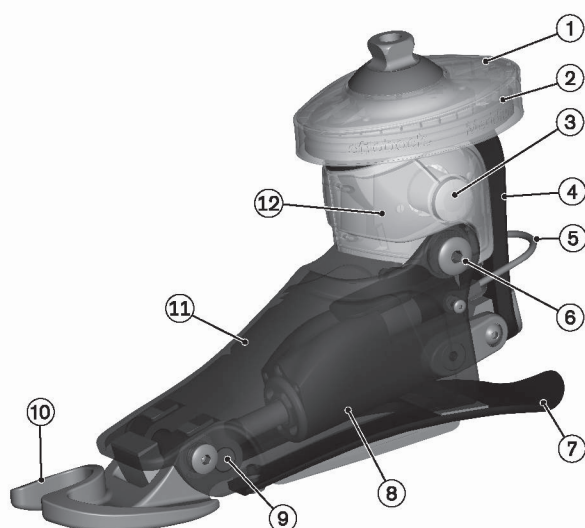

1. Cover/connection plate
2. Cover cap with charging receptacle
3. Battery
4. Ankle spring
5. Heel bracket
6. Ankle axis
7. Heel spring
8. Hydraulic unit
9. Toe axis
10. Toe plate
11. Carbon fibre frame
12. Main electronics

2.2 Function

This product features microprocessor-controlled damping of plantar flexion (motion of the foot in the ankle joint in the direction of the sole of the foot) and dorsiflexion (motion of the foot in the ankle joint in the direction of the instep).

The microprocessor uses the measurements of an integrated sensor system as a basis to control a hydraulic unit that influences the damping behaviour of the product.

These sensor data are updated and evaluated 100 times per second. As a result, the behaviour of the product is adapted to the current motion situation (gait phase) dynamically and in real time.

Thanks to the microprocessor-controlled damping of the plantar flexion and dorsiflexion, the product can be individually adapted to the needs of the patient.

For this purpose, the product is configured with the "M-Soft" adjustment software.

The product features MyModes for special motion types (e.g. golf ...). These modes have default values provided through the adjustment software, which can be called up via remote control or through a special motion pattern (see Page 27).

Additionally, provided it is configured using the adjustment software, a so-called lock mode (additional mode "Ankle lock") can also be selected, locking the ankle joint of the prosthetic foot in its current position.

In case of a system malfunction, safety mode makes restricted operation possible. Predefined resistance parameters are configured in the product for this purpose (see Page 33).

Empty battery mode permits safe walking when the battery is drained. Resistance parameters that are predefined by the product are configured for this purpose (see Page 32).

The microprocessor-controlled hydraulic unit offers the following advantages

- Approximation of the physiological gait pattern
- Stability while standing and walking
- Adaptation of product characteristics to various surfaces, inclines, gait situations, walking speeds and heel heights

2.3 Combination possibilities

This product can be combined with the following Ottobock components:

Knee joints

- Genium: 3B1, 3B1=ST, 3B1-2, 3B1-2=ST
- Genium X3: 3B5-X3, 3B5-X3=ST, 3B5-2, 3B5-2=ST
- 3C98-2, 3C88-2 C-Leg knee joint
- 3C98-3, 3C88-3 C-Leg

Cosmetic cover/protector

- 4X860=* C-Leg Protective Cover (w/o shield)
- 4X880=* Genium Protector
- 4X889=1 SF Genium Protector
- 3S26 cosmetic foam cover

Footshells

- Translucent: 2C7=[prosthesis side][foot size]/1
- Beige: 2C7=[prosthesis side][foot size]/4
- Brown: 2C7=[prosthesis side][foot size]/15

[prosthesis side]: L=left, R=right

[foot size]: 24, 25, 26, 27, 28, 29

Order example: Footshell for left prosthetic foot in foot size 25 and beige colour

Article number: 2C7=L25/4

3 Application

3.1 Indications for use

The product is to be used **solely** for lower limb exoprosthetic fittings.

3.2 Area of application

Area of application according to the MOBIS mobility system:

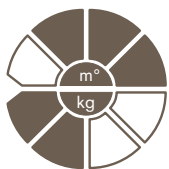

The product is recommended for mobility grade 2 (restricted outdoor walker), mobility grade 3 (unrestricted outdoor walker) and mobility grade 4 (unrestricted outdoor walker with particularly high demands). Approved for a body weight of up to **100 kg (220 lbs)**.

3.3 Conditions of use

The product was developed for everyday use and must not be used for unusual activities. These unusual activities include, for example, sports with excessive impact load (tennis, basketball, running, ...) or extreme sports (free climbing, paragliding, etc.).

Permissible ambient conditions are described in the technical data (see Page 39).

The product is intended **exclusively** for use on **one** patient. Use of the product by another person is not approved by the manufacturer.

3.4 Service Life

The product is a wear part, which means it is subject to natural wear and tear. The service life diminishes or increases depending on the individual level of use. Only when the instructions for use are observed it is possible to achieve the maximal service life, in dependence of the level of use.

This product has been tested by the manufacturer with 2 million load cycles according to ISO 22675. Depending on the patient's activity level, this corresponds to a service life of 2 to 3 years.

3.5 Indications



- For users with unilateral knee disarticulation and unilateral transfemoral amputation
- For users with unilateral or bilateral transtibial amputation
- The user must fulfil the physical and mental requirements for perceiving optical/acoustic signals and/or mechanical vibrations

3.6 Qualification

The product may be fitted only by qualified personnel authorised by Ottobock after completing the corresponding training.

4 Safety

4.1 Explanation of warning symbols

 WARNING	Warning regarding possible serious risks of accident or injury.
 CAUTION	Warning regarding possible risks of accident or injury.
 NOTICE	Warning regarding possible technical damage.

4.2 Structure of the safety instructions

<p> CAUTION</p> <p>The heading describes the source and/or the type of hazard</p> <p>The introduction describes the consequences in case of failure to observe the safety instructions. Consequences are presented as follows if more than one consequence is possible:</p> <ul style="list-style-type: none"> > E.g.: Consequence 1 in case of failure to observe the hazard > E.g.: Consequence 2 in case of failure to observe the hazard <p>▶ This symbol identifies activities/actions that must be observed/carried out in order to avert the hazard.</p>
--

4.3 General safety instructions

<p> WARNING</p> <p>Use of damaged power supply unit, adapter plug or battery charger</p> <p>Risk of electric shock due to contact with exposed, live components.</p> <ul style="list-style-type: none"> ▶ Do not open the power supply unit, adapter plug or battery charger. ▶ Do not expose the power supply unit, adapter plug or battery charger to extreme loading conditions. ▶ Immediately replace damaged power supply units, adapter plugs or battery chargers.
--

<p> CAUTION</p> <p>Failure to observe warning/error signals</p> <p>Falling due to unexpected behaviour of the product because of changed damping behaviour.</p> <ul style="list-style-type: none"> ▶ Observe the warning/error signals, the errors that appear on the remote control display (see Page 37) and the corresponding change in damping settings.
--

⚠ CAUTION**Independent user manipulation of system components**

Falling due to breakage of load-bearing components or malfunction of the product.

- ▶ Manipulations to the product other than the tasks described in these instructions for use are not permitted.
- ▶ The battery may only be handled by Ottobock authorised, qualified personnel (no replacement by the user).
- ▶ The product and any damaged components may only be opened and repaired by authorised, qualified Ottobock personnel.

⚠ CAUTION**Mechanical stress on the product**

- > Falling due to unexpected product behaviour as the result of a malfunction.
- > Falling due to breakage of load-bearing components.
- > Skin irritation due to defects on the hydraulic unit with leakage of liquid.
- ▶ Do not subject the product to mechanical vibrations or impacts.
- ▶ Check the product for visible damage before each use.

⚠ CAUTION**Use of the product when battery charge level is too low**

Falling due to unexpected behaviour of the prosthesis because of changed damping behaviour.

- ▶ Check the current charge level before use and charge the prosthesis if required.
- ▶ Note that the operating time of the product may be reduced at low ambient temperatures or due to ageing of the battery.

⚠ CAUTION**Penetration of liquid into system components**

Falling due to unexpected product behaviour as the result of malfunction.

- ▶ When the footshell is intact, the prosthesis is protected against splashed water from all directions. However, it is not protected against submersion, jets of water and steam.
- ▶ If water has penetrated system components, remove the footshell and allow the components to dry. The prosthesis must be inspected by an authorised Ottobock Service Centre.
- ▶ If salt water has penetrated the prosthesis, the footshell must be removed immediately. The prosthesis must be inspected by an authorised Ottobock Service Centre.
- ▶ Do not use the product for bathing prostheses.

⚠ CAUTION**Overloading due to unusual activities**

- > Falling due to unexpected product behaviour as the result of malfunction.
- > Falling due to breakage of load-bearing components.
- > Skin irritation due to defects on the hydraulic unit with leakage of liquid.
- ▶ The product was developed for everyday use and must not be used for unusual activities. These unusual activities include, for example, sports with excessive impact load (tennis, basketball, running, ...) or extreme sports (free climbing, paragliding, etc.).
- ▶ Careful handling of the product and its components not only increases their service life but, above all, ensures the patient's personal safety!
- ▶ If the product and its components have been subjected to extreme loads (e.g. due to a fall, etc.), then the product must be inspected for damage immediately. If necessary, forward the product to an authorised Ottobock Service Centre.

⚠ CAUTION**Mechanical stress during transport**

- > Falling due to unexpected product behaviour as a result of a malfunction.
- > Falling due to breakage of load-bearing components.
- > Skin irritation due to defects on the hydraulic unit with leakage of liquid.
- ▶ Only use the transport packaging for transportation.

⚠ CAUTION**Signs of wear to system components**

Falling due to damage or malfunction of the product.

- ▶ In the interest of the patient's safety and in order to maintain operating reliability, the product should be serviced at regular intervals.

NOTICE**Improper product care**

Damage to the product due to the use of incorrect cleaning agents.

- ▶ Only clean the product with a damp cloth and mild soap (e.g. 453H10=1 Ottobock DermaClean).

NOTICE**Mechanical damage to the product**

Change in or loss of functionality due to damage.

- ▶ Use caution when working with the product.
- ▶ If the product is damaged, check it for proper function and readiness for use.
- ▶ In case of changes in or loss of functionality, do not continue using the product (see "Signs of changes in or loss of functionality during use" in this section).
- ▶ Take any necessary measures (e.g. repair, replacement, inspection by the manufacturer's customer service, etc.).

INFORMATION

When exoprosthetic components are used, the use of control functions which are performed hydraulically or movement of the component in the footshell can cause movement noise. This kind of noise is normal and unavoidable. It generally does not cause any problems. If movement noise increases noticeably during the lifecycle of the component, the component should be inspected by an authorised Ottobock Service Centre immediately.

Signs of changes in or loss of functionality during use

Reduced spring effect (e.g. decreased forefoot resistance or changed rollover characteristics) is an indication of loss of functionality.

4.4 Information on the Power Supply/Battery Charging**⚠ CAUTION****Charging the prosthesis without taking it off**

- > Falling due to walking and getting caught on the connected battery charger.
- > Falling due to unexpected behaviour of the prosthesis because of changed damping behaviour.
- ▶ Instruct the patient that the prosthesis must be taken off before it is charged.

⚠ CAUTION**Charging the product with damaged power supply unit/charger/charger cable**

Falling due to unexpected behaviour of the product caused by insufficient charging.

- ▶ Check the power supply unit, charger and charger cable for damage before use.
- ▶ Replace any damaged power supply unit, charger or charger cable.

NOTICE**Use of incorrect power supply unit/battery charger**

Damage to product due to incorrect voltage, current or polarity.

- ▶ Use only power supply units/battery chargers approved for this product by Ottobock (see instructions for use and catalogues).

4.5 Battery charger information

NOTICE

Penetration of dirt and humidity into the product

Lack of proper charging functionality due to malfunction.

- ▶ Ensure that neither solid particles nor liquids can penetrate into the product.

NOTICE

Mechanical stress on the power supply/battery charger

Lack of proper charging functionality due to malfunction.

- ▶ Do not subject the power supply/battery charger to mechanical vibrations or impacts.
- ▶ Check the power supply/battery charger for visible damage before each use.

NOTICE

Operating the power supply unit/charger outside of the permissible temperature range

Lack of proper charging functionality due to malfunction.

- ▶ Only use the power supply unit/charger for charging within the allowable temperature range. The section "Technical data" contains information on the allowable temperature range (see Page 39).

NOTICE

Independent changes or modifications carried out to the battery charger

Lack of proper charging functionality due to malfunction.

- ▶ Have any changes or modifications carried out only by Ottobock authorised, qualified personnel.

4.6 Information on Alignment/Adjustment

⚠ CAUTION

Use of unsuitable prosthesis components

Falling due to unexpected behaviour of the product or breakage of load-bearing components.

- ▶ Use the product only in combination with components listed in the section "Combination possibilities" (see Page 8).

⚠ CAUTION

Incorrect alignment or assembly

Falling due to damage to the prosthesis components.

- ▶ Observe the alignment and assembly instructions.

⚠ CAUTION

Disconnecting/establishing the connection during the adjustment process with the adjustment software

Falling due to unexpected behaviour of the product.

- ▶ When wearing the product, the patient must not remain unattended during the configuration process while connected to the adjustment software.
- ▶ Observe the maximum range of the Bluetooth connection.
- ▶ During the data transfer (PC to product), the patient must stand or sit without moving.
- ▶ If the connection fails while making adjustments, the prosthetist must immediately warn and secure the patient.
- ▶ The connection to the product must always be disconnected after adjustments have been completed.

⚠ CAUTION**Operator errors during the adjustment process with the adjustment software**

Falling due to unexpected behaviour of the product.

- ▶ Participation in an Ottobock product training course is mandatory prior to using the product. Additional product training courses may become necessary to qualify for software updates.
- ▶ Correctly entering the patient data (e.g. body weight) is an important criterion for the quality of the fitting.
- ▶ Always enter the weight in the specified unit.
- ▶ Ensure that the required dimensions are selected and entered correctly.
- ▶ If the patient uses walking aids (e.g. crutches or walking canes) during the adjustment process, readjustment is required as soon as the patient stops using these walking aids.

4.7 Information on Proximity to Certain Areas**⚠ CAUTION****Distance to HF communication devices is too small (e.g. mobile phones, Bluetooth devices, WiFi devices)**

Falling due to unexpected behaviour of the product caused by interference with internal data communication.

- ▶ Therefore, keeping the following minimum distances to these HF communication devices is recommended:
 - Mobile phone GSM 850/GSM 900: 0.50 m
 - Mobile phone GSM 1800/GSM 1900/UMTS: 0.35 m
 - DECT cordless phones incl. base station: 0.18 m
 - WiFi (routers, access points,...): 0.11 m
 - Bluetooth devices (third-party products not approved by Ottobock): 0.11 m

⚠ CAUTION**Proximity to sources of strong magnetic or electrical interference (e.g. theft prevention systems, metal detectors)**

Falling due to unexpected behaviour of the product caused by interference with internal data communication.

- ▶ Ensure that the patient is not in the vicinity of sources of strong magnetic and electrical interference during trial fitting (e.g. computer tomographs, magnetic resonance tomographs ...).
If this cannot be avoided, ensure at least that the patient is able to walk or stand securely (e.g. by using a handrail or the support of another person).

⚠ CAUTION**Remaining in areas outside the allowable temperature range**

Falling due to malfunction or the breakage of load-bearing product components.

- ▶ Ensure that the patient is not in areas outside the permissible temperature range (see Page 39) during trial fitting.

4.8 Information on Use**⚠ CAUTION****Walking up stairs**

Falling due to foot placed incorrectly on stair.

- ▶ Ensure that the patient uses the handrail when walking up stairs and places most of the sole of the foot on the stair surface. The toe plate may fold away if only the front part of the foot is placed on the edge of the stair.
- ▶ Inform the patient that particular caution is required when carrying children while walking up stairs.

⚠ CAUTION**Walking down stairs**

Falling due to foot being placed incorrectly on stair as a result of changed damping behaviour.

- ▶ Ensure that the patient uses the handrail when walking down stairs and places most of the sole of the foot on the stair surface. Rolling the foot over the edge of the stair is not necessary.
- ▶ Inform the patient that particular caution is required when carrying children while walking down stairs.

⚠ CAUTION

Overheating of the hydraulic unit due to uninterrupted, increased activity (e.g. extended walking downhill)

Falling due to unexpected behaviour of the product because of switching into overheating mode.

- ▶ Be sure to pay attention when pulsating vibration signals start. They indicate the risk of overheating.
- ▶ As soon as these pulsating vibration signals begin, you have to reduce the activity level so the hydraulic unit can cool down.
- ▶ When the product is in overheating mode, it does not make automatic adjustments to damping while walking on ramps or stairs. Special caution is therefore required, especially when walking down stairs.
- ▶ Full activity may be resumed after the pulsating vibration signals stop.
- ▶ If the activity level is not reduced in spite of the pulsating vibration signals, this could lead to the hydraulic element overheating and, in extreme cases, cause damage to the product. In this case, the product should be inspected by an authorised Ottobock Service Centre.

⚠ CAUTION

Improper mode switching

Falling due to unexpected behaviour of the product because of changed damping behaviour.

- ▶ Ensure that the patient stands securely during all switching processes.
- ▶ Inform the patient that the changed damping characteristics have to be verified after switching and feedback from the acoustic signal emitter must be observed.
- ▶ Switching back to basic mode is mandatory once the activities in MyMode have been completed.
- ▶ If required, take the weight off the product and correct the switching.

⚠ CAUTION

Using prosthetic foot without footshell

Falling due to slipping when walking on smooth floor surfaces (tiles).

- ▶ Do not use the prosthetic foot without the accompanying footshell.

⚠ CAUTION

Using prosthetic foot with a damaged foot shell

> Falling due to unexpected product behaviour as the result of malfunction.

> Falling due to breakage of load-bearing components.

- ▶ Do not use the prosthetic foot when the foot shell is damaged. Replace damaged foot shells immediately, before using the product again.

4.9 Notes on the safety modes

⚠ CAUTION

Using the product in safety mode

Falling due to unexpected product behaviour because of changed damping behaviour.

- ▶ The warnings/error signals (see Page 37) have to be observed.

⚠ CAUTION

Safety mode cannot be activated due to malfunction caused by water penetration or mechanical damage

Falling due to unexpected product behaviour because of changed damping behaviour.

- ▶ Using the product when it is defective is prohibited.
- ▶ The product must be inspected by an authorised Ottobock Service Centre.

⚠ CAUTION

Safety mode cannot be deactivated

Falling due to unexpected product behaviour because of changed damping behaviour.

- ▶ If you cannot deactivate safety mode by recharging the battery, a permanent malfunction has occurred.
- ▶ Do not continue using the defective product.
- ▶ The product must be inspected by an authorised Ottobock Service Centre.

⚠ CAUTION**Safety signal occurs (ongoing vibration)**

Falling due to unexpected product behaviour because of changed damping behaviour.

- ▶ The warnings/error signals (see Page 37) have to be observed.
- ▶ After the safety signal has been emitted, further use of the product is prohibited.
- ▶ The product must be inspected by an authorised Ottobock Service Centre.

4.10 Information on the use of a mobile device with the cockpit app**⚠ CAUTION****Improper use of the device**

Falling due to altered damping behaviour as a result of unexpected switching into MyMode.

- ▶ Use the instructions for use (user) to instruct the patient on proper use of the device with the cockpit app.

⚠ CAUTION**Independently applied changes or modifications made to the device**

Falling due to altered damping behaviour as a result of unexpected switching into MyMode.

- ▶ Do not make any independent changes to the hardware of the device.
- ▶ Do not make any independent changes to the software/firmware of the device which are not included in the update function of the software/firmware.

⚠ CAUTION**Improper mode switching with the device**

Falling due to unexpected product behaviour because of changed damping behaviour.

- ▶ Ensure that the patient stands securely during all switching processes.
- ▶ Inform the patient that the changed damping characteristics have to be verified after switching, and feedback from the acoustic signal emitter and the device display must be observed.
- ▶ Switching back to basic mode is mandatory once the activities in MyMode have been completed.

NOTICE**Destruction of the device due to falling or penetration of water**

Malfunction of the device.

- ▶ If necessary, let the device dry at room temperature (at least 1 day).
- ▶ If it should no longer be possible to switch back from a MyMode to basic mode, the component can only be switched back to basic mode by using a movement pattern (see Page 29) or by connecting/disconnecting the battery charger.

NOTICE**Failure to observe the system requirements for the installation of the cockpit app**

Malfunction of the device.

- ▶ Install the cockpit app only on the operating systems listed in the section "System requirements" (see Page 20). The tested devices are listed in this section as well.

5 Scope of Delivery and Accessories**Scope of Delivery**

- 1 pc. 1B1 Meridium
- 1 pc. 757L16* power supply
- 1 pc. 4E50 Battery Charger for C-Leg
- 1 pc. 646C107 Bluetooth PIN card
- 1 pc. 647G869 instructions for use (user)
- 1 pc. 647G870 instructions for use (qualified personnel)
- 1 pc. 2C7 footshell inc. instructions for use
- 1 pc. 4G872=* set of cover caps

- 1 pc. 2C101 footshell replacement tool
- Android app "Cockpit 4X441-Andr=V*" for download from the website: <http://www.ottobock.com/cockpitapp>

Accessories

The following components are not included in the scope of delivery and may be ordered separately:

- 60X5 BionicLink PC
- 1 4X350 remote control
- 1 pc. 757P48 Y adapter cable
This is for charging more than one product at the same time (e.g. 1B1; 3B1/3B1=ST; 3B1-2/3B1-2=ST; 3B5-X3/3B5-X3=ST; 3C98-2/3C88-2; 3C98-3/3C88-3; 3C96-1/3C86-1) with the 757L16* power supply.
- 704G30 clamping tool

6 Charging the battery

The following points must be observed when charging the battery:

- The capacity of a fully charged battery is sufficient for one full day.
- We recommend charging the product overnight when used by the patient on a daily basis.
- When used daily, the complete charging unit (power supply – battery charger) may remain plugged into the wall socket.
- For the maximum operating time with one battery charge, disconnecting the battery charger from the product only immediately before using the product is recommended.
- The battery should be charged until the yellow LED on the battery charger turns off prior to initial use, and for at least 4 hours. This calibrates the charge level indicator via the Cockpit app/remote control and by turning over the prosthesis.

If the battery charger is disconnected from the prosthesis too soon, the charge level indicator via the Cockpit app/remote control and by turning over the prosthesis may not correspond to the actual charge level.

- Use the 757L16* power supply and 4E50* battery charger to charge the battery.
- The ankle joint of the prosthetic foot is locked during the charging process.
- The battery may discharge while the product is not being used.

6.1 Connecting the power supply and battery charger

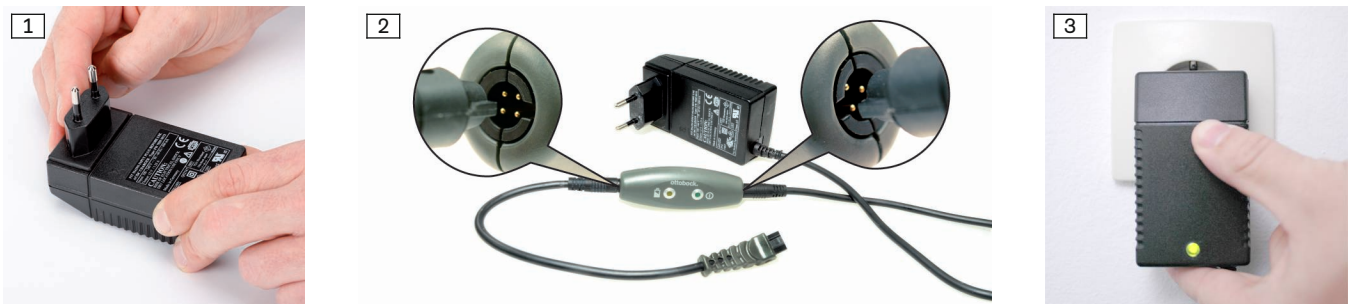

- 1) Slide the country-specific plug adapter onto the power supply until it locks into place (see fig. 1).
- 2) Connect the round, **three-pin** plug of the power supply to the **12V** receptacle on the battery charger so that the plug locks into place (see fig. 2).
INFORMATION: Ensure correct polarity (guide lug). Do not use force when connecting the cable plug to the battery charger.
- 3) Connect the round, **four-pin** plug of the charging cable to the **OUT** receptacle on the battery charger so that the plug locks into place (see fig. 2).
INFORMATION: Ensure correct polarity (guide lug). Do not use force when connecting the cable plug to the battery charger.
- 4) Plug the power supply unit into the wall socket.
→ The green LED on the back of the power supply and the green LED on the battery charger light up (see fig. 3).
→ If the green LED on the power supply and the green LED on the battery charger do not light up, there is an error (see Page 37).

6.2 Charging the prosthesis battery



- 1) Open the charging receptacle cover.
- 2) Connect the charging plug to the charging receptacle of the product.
INFORMATION: Take note of the plug direction!
→ The correct connection of the battery charger to the product is indicated by feedback (see Page 39).
- 3) The charging process starts.
→ Once the product battery is fully charged, the yellow LED on the battery charger turns off.
- 4) Disconnect the product after the charging process is complete.
→ This is followed by an electronics self-test which is confirmed by feedback (see Page 39).
- 5) Close the charging receptacle cover.

6.3 Display of the current charge level



- 1) Turn the prosthesis by 180° (the sole of the foot must face up).
- 2) Hold the prosthesis still and wait for beep signals.
Prosthetic foot with knee joint:
The beep signal for the knee joint sounds after approx. 2 seconds.
The beep signal for the prosthetic foot sounds after approx. 4 seconds.
Prosthetic foot without knee joint:
The beep signal for the prosthetic foot sounds after approx. 2 seconds.

Beep signal	Vibration signal	Battery charge level
5x short		more than 80%
4x short		66% to 80%
3x short		51% to 65%
2x short		36% to 50%
1x short	3x long	20% to 35%
1x short	5x long	less than 20%

INFORMATION

If the **VOLUME** parameter is set to '0' in the Cockpit app or using the remote control, there are no beep signals (see Page 29).

Display of the current charge level using the cockpit app:

Once the cockpit app has been started, the current charge level is displayed in the bottom line of the screen:



1. 38% – battery charge level of currently connected prosthesis

Display of current charge level using remote control:

The current charge level is displayed in the status bar of the remote control when it is connected and switched on:

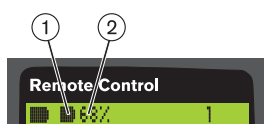

1. – Charge level of battery for currently connected prosthesis
 – Prosthesis is being charged
2. 68% – Charge level of battery for currently connected prosthesis, as a percentage

7 Preparation for use

7.1 Applying/removing footshell

For applying/removing the footshell, please consult the instructions for use included with the footshell.

CAUTION

Incorrect assembly/disassembly and improper use of footshell

- > Falling due to unexpected product behaviour as the result of malfunction.
- > Falling due to breakage of load-bearing components.
- ▶ Use the prosthetic foot only in combination with the footshell.
- ▶ Remove the footshell from the prosthetic foot only when necessary.
- ▶ Only use the 2C101 changing device and the 704G30 clamping device for mounting/removing.
- ▶ Replace worn footshells. Do not use the prosthetic foot when the footshell is damaged.

INFORMATION

Before putting on the footshell, make a note of the serial number of the component. This is located in the upper area of the ankle spring and can be read by removing the cover cap. The serial number is also located on the spherical cap.

The serial number is required to connect to the adjustment software, to connect to the remote control unit, and for entry in the prosthesis passport.

7.2 Alignment

7.2.1 Bench alignment in alignment apparatus

With correct bench alignment, e.g. in the PROS.A. assembly alignment apparatus (743A200), the benefits of the product are realised to best advantage. If the L.A.S.A.R. assembly alignment apparatus (743L200) is available, it can be used as well.

Alignment can also be carried out using LaserLine/plumb line.

The following points must be observed during alignment:

- The alignment recommendations provided must be observed in order for the prosthetic foot to function correctly.
- Static alignment in the **alignment apparatus** must always be carried out **without shoes**, otherwise a correct adjustment will not be possible.
- A marking is located on the exterior distal side of the footshell. The marking serves as orientation for the alignment point on the foot.
- Before beginning the alignment, the prosthetic foot must be put into alignment mode using the adjustment software ("Alignment" tab, "Alignment Recommendation" tab). Only in alignment mode will the prosthetic foot be locked in neutral position and allow static alignment to be carried out correctly.

Foot size (cm)	Mid-foot anterior to the alignment reference line	Heel height
24 – 29	30 mm	0 mm

Bench alignment for transtibial (TT) modular lower limb prostheses

The adjustment software must be used to provide information for alignment of TT modular lower limb prostheses (also see TT modular lower limb prostheses: 646F336).

Bench alignment for transfemoral (TF) modular lower limb prostheses

The alignment recommendations for the appropriate Ottobock knee joint must be observed for TF modular lower limb prostheses (also see TF modular prostheses: 646F219).

7.2.2 Static alignment optimisation

- Use the L.A.S.A.R. Posture for static alignment optimisation of the prosthesis, if available.
- Use the alignment recommendations of the manufacturer (TF modular lower limb prostheses: **646F219**, TT modular lower limb prostheses: **646F336**).

7.2.3 Dynamic alignment optimisation

Make sure the heel height is correctly set before beginning the dynamic alignment optimisation!

- Dynamic alignment optimisation is not necessary if the static situation is satisfactory. The adjustment software is used to make adjustments to ensure correct heel contact, smooth rollover and optimum weight transfer on the contralateral side.
- Adjust the prosthesis in the frontal plane (ML) by using the medial-lateral screws to change its angle or shift it (see 646F336) so as to minimise any axial run-out in the knee.

7.2.4 Mounting cover plate/connecting plate/cover cap

Depending on the cosmetic that is being used (cosmetic foam cover, Protector), the suitable element must be selected from the set of cover caps and mounted on the product.

7.2.4.1 Mounting the cover cap



The cover cap forms the top of the footshell.

- ▶ Mount the cover cap according to the 647G977 instructions for use.

7.2.4.2 Mounting the cover plate

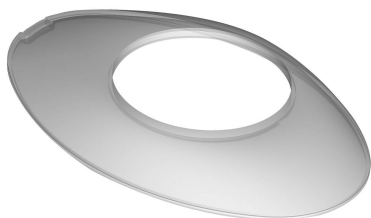

If the cover plate is being used, there should be no cosmetic (Protector, cosmetic foam cover) on the product.

- ▶ Fit the cover plate on the cover cap which has already been mounted.

7.2.4.3 Mounting the Protector connecting plate

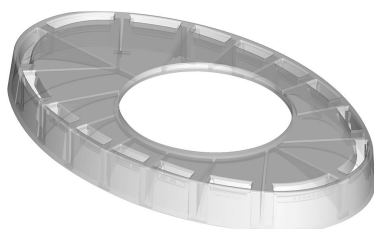

The Protective Cover connecting plate acts as the connection between the prosthetic foot and the Protective Cover.

- 1) Apply adhesive to the cover cap in 4 places (adhesive areas about 15 mm long).
- 2) Fit the Protective Cover connecting plate to the cover cap which has already been mounted.
- 3) Fasten the clips of the foot cuff to the Protective Cover connecting plate.

INFORMATION: Please note the 647G1113 instructions for use.

7.2.4.4 Mounting the connecting plate for the cosmetic foam cover

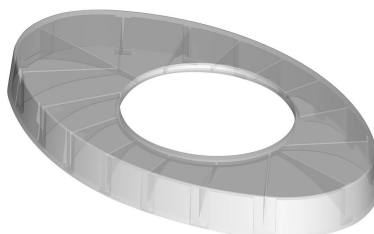

The connecting plate for the cosmetic foam cover acts as the connection between the prosthetic foot and the cosmetic foam cover.

- 1) Fit the connecting plate for the cosmetic foam cover to the cover cap which has already been mounted.
- 2) Trim the cosmetic foam cover to fit the connecting plate for the cosmetic foam cover.
- 3) Apply a layer of 636N9 contact adhesive to the contact surfaces of the cosmetic foam cover.
- 4) Place the cosmetic foam cover on the connecting plate for the cosmetic foam cover.

8 Cockpit app



The cockpit app enables switching from basic mode into the pre-configured MyModes. In addition, information about the product (step counter, battery charge level, etc.) can be called up.

The behaviour of the product can be changed to a certain extent on a day-to-day basis using the app (e.g. while becoming accustomed to the product). The adjustment software can be used to trace the change at the patient's next appointment.

INFORMATION

The Cockpit app can be downloaded free of charge from the respective online store. For more information, please visit the website: <http://www.ottobock.com/cockpitapp>. To download the Cockpit app, the QR code on the supplied Bluetooth PIN card can be read with the mobile device (requirement: QR code reader and camera).

8.1 System Requirements

The functioning of the cockpit app is assured on devices with the Android operating system version 4.0.3 or higher. The functionality was tested on the following devices:

- Samsung Galaxy S5, Galaxy S4, Galaxy S4 mini, Galaxy SIII, Galaxy SIII mini, Galaxy Note II, Galaxy Fame
- Sony Xperia Z, Xperia Z3, Xperia J, Xperia SP
- HTC One, One mini
- LG Optimus L9, Optimus F5, Optimus F6, Optimus G, Optimus G2
- Huawei Ascend P6, Ascend G500
- Motorola Droid Razr Maxx, Moto X, Nexus 6

8.2 Initial connection between cockpit app and prosthesis

The following points should be observed before the initial connection:

- Bluetooth of the component must be switched on.
If Bluetooth is switched off, it can be turned on by turning the prosthesis upside-down (sole of the foot must point up) or by connecting/disconnecting the battery charger. Bluetooth is then turned on for approx. 2 minutes. During this time, the app must be started and used to establish a connection. If required, Bluetooth on the prosthesis can be switched on permanently afterwards (see Page 32).
- Bluetooth of the device must be switched on.
- The device must not be in "flight mode" (offline mode), otherwise all wireless connections are turned off.
- **The device must be connected to the internet.**
- The serial number and PIN code of the component being connected must be known. They are found on the enclosed Bluetooth PIN card. The serial number begins with the letters "SN".

INFORMATION



If the Bluetooth PIN card with the PIN code and serial number of the component is lost, contact an authorised Ottobock service centre. The serial number must be provided so a new card can be issued. This begins with the letters SN and is found in the following position depending on the component:

Knee joints: On the inside of the frame.

Prosthetic feet: On the spherical cap.

8.2.1 Starting the cockpit app for the first time

- 1) Tap the symbol of the Cockpit app ().
→ The end user license agreement (EULA) is displayed.
- 2) Accept the end user license agreement (EULA) by tapping the **Accept** button. If the end user license agreement (EULA) is not accepted, the Cockpit app cannot be used.
→ The welcome screen appears.
- 3) Tap the **Add component** button.
→ The **"Preparation"** screen appears. The serial number of the component should be entered here.





- 4) Follow the subsequent instructions on the screen.
- 5) After the PIN code is entered, a connection to the prosthesis is established.
 - While the connection is being established, 3 beep signals sound and the  symbol appears.
 - The  symbol is displayed when the connection has been established.
- Once the connection has been established successfully, the data are read from the prosthesis. This process may take up to a minute.
- The main menu will then appear with the name of the connected prosthesis.

INFORMATION

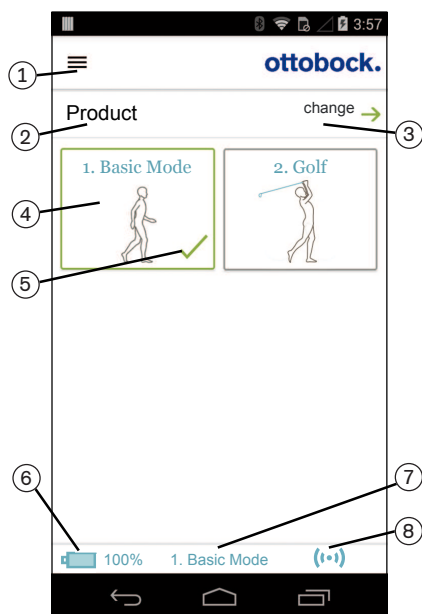
After the initial connection to the prosthesis has been established successfully, the app will connect automatically each time it is started. No further steps are required.

8.3 Control elements for cockpit app



1.  Call up the navigation menu (see Page 22)
2. Product
The component name can only be changed with the adjustment software.
3. If connections to more than one component have been saved, you can switch between the saved components by tapping the entry **change** (see Page 22).
4. MyModes configured with the adjustment software.
Switching the mode by tapping the corresponding symbol and confirming by tapping "**OK**".
5. Currently selected mode
6. Charge level of the component.
 -  Component battery fully charged
 -  Component battery empty
 The current charge level is also displayed in %.
7. Display and name of the currently selected mode (e.g. **1. Basic Mode**)
8.  Connection to component has been established
 Connection to component has been interrupted. The app is attempting to re-establish the connection automatically.

8.3.1 Cockpit app navigation menu

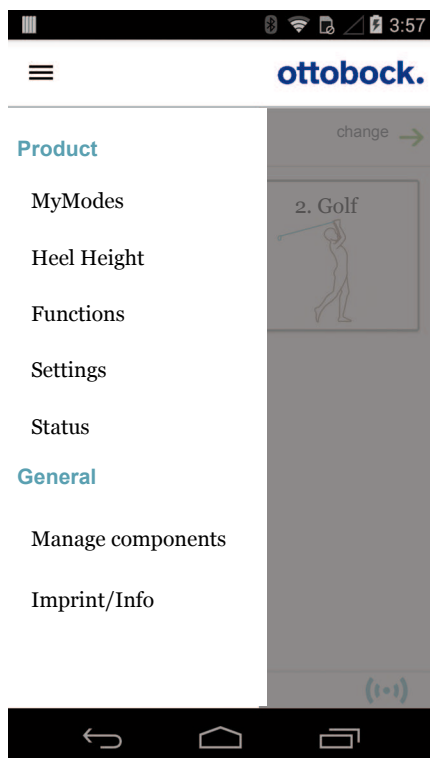

Tap the ☰ symbol in the menus to display the navigation menu. Additional settings for the connected component can be configured in this menu.

Product

Name of the connected component

MyModes

Return to the main menu to switch MyModes

Heel Height

Setting the heel height (see Page 23)

Functions

Call up additional functions of the component (e.g. turn off Bluetooth) (see Page 32)

Settings

Change settings of the selected mode (see Page 29)

Status

Query status of the connected component (see Page 32)

Manage components

Add or delete components (see Page 22)

Imprint/Info

Display information/legal notices for the cockpit app

8.4 Managing prostheses

Connections with up to four different components can be stored in the app. However, a component can only be connected to one device or remote control at a time.

Adding component

- 1) Tap the ☰ symbol in the main menu.
 - The navigation menu opens.
- 2) In the navigation menu, tap the entry "**Manage components**".
- 3) In the following screen, tap the "**Add component**" button.
 - The "Preparation" screen appears. The serial number of the component should be entered here. The serial number begins with the letters "SN".
- 4) Follow the subsequent instructions on the screen.
- 5) After the PIN code is entered, a connection to the prosthesis is established.
 - While the connection is being established, 3 beep signals sound and the (i) symbol appears. The (i) symbol is displayed when the connection has been established.
 - Once the connection has been established successfully, the data are read from the prosthesis. This process may take up to a minute. The main menu will then appear with the name of the connected prosthesis.

Deleting a component

- 1) Tap the ☰ symbol in the main menu.
 - The navigation menu opens.
- 2) In the navigation menu, tap the entry "**Manage components**".
- 3) Tap the ☒ symbol under the component you want to delete.
 - The component is deleted.

Connecting component with multiple devices

The connection for a component can be stored on more than one device. However, only one device or remote control can be connected to the component at one time.

If there is an existing connection between the component and a different device, the following information appears while the connection is being established with the current device:

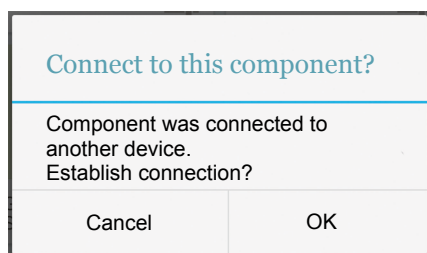

- ▶ Tap the **OK** button.
- The connection to the last connected device is broken off and established with the current device.

9 Use

9.1 Setting the heel height

The heel height of the prosthesis must be set on a level surface. A sloped ground surface distorts the heel height measurement and leads to improper control of damping behaviour.

A heel height that is too high may cause control of the prosthetic foot to function incorrectly because of too little motion in the ankle joint. This occurs especially in case of small feet, heels that are moved forward, when walking down stairs and ramps, and standing on surfaces that are sloping downwards. The maximum heel height in the section "Technical data" must therefore be taken into account (see Page 39).

9.1.1 Setting heel height using motion pattern

- 1) Put on shoes with the new heel height.
 - 2) Stretch out foot with the prosthetic foot sideways.
 - 3) Swing the foot to the side three times.
 - A beep signal will sound to confirm that the motion pattern has been recognised.
 - 4) Put feet at the same level and make sure the heel and toes are resting on the ground surface.
 - 5) Distribute weight on feet evenly.
 - A confirmation signal will sound to indicate that the new heel height was successfully stored.
- INFORMATION: If there is no feedback (e.g. beep signal), this indicates that the new heel height could not be stored. Repeat the heel height measurement.**

9.1.2 Setting the heel height with the cockpit app

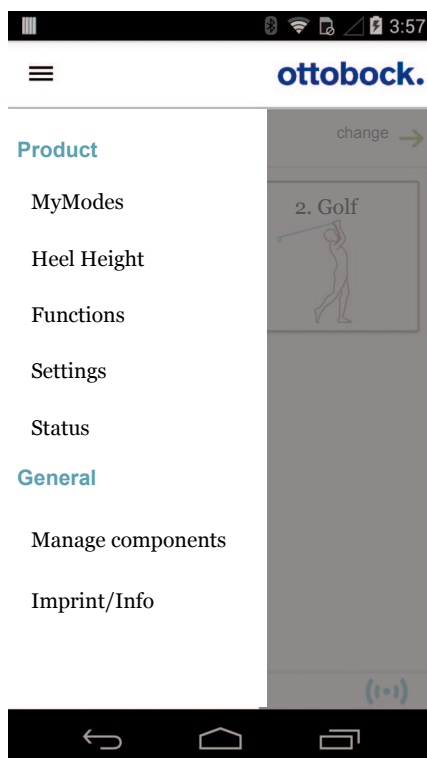

- 1) Once the component is connected and in the desired mode, tap the ☰ symbol in the main menu.
 - The navigation menu opens.
- 2) Tap the "**Heel Height**" menu option.
- 3) Follow the on-screen instructions.
- 4) Tap the "**Set the heel height**" option.
- 5) Follow the subsequent instructions on the screen.

9.1.3 Setting heel height using remote control

INFORMATION

This function is not available while the battery of the prosthesis is being charged. The  symbol appears in front of the "STATUS" menu option.

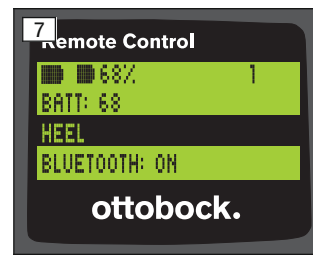
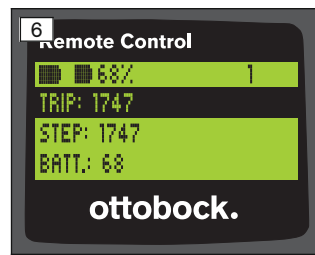
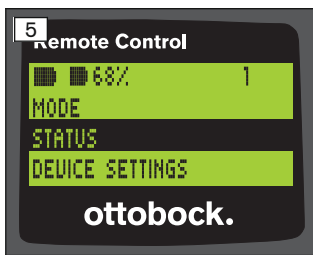

- 1) Use the ▲, ▼ keys to select the menu option "STATUS" in the main menu and confirm this with the ■ key.
- 2) Use the ▲, ▼ keys to select the "HEEL HEIGHT" menu option.
- 3) Stand on a level surface and distribute weight evenly on both feet.
- 4) Press the ■ key to start the heel height measurement.

→ A confirmation signal will sound to indicate that the new heel height was successfully stored.

INFORMATION: If there is no feedback (e.g. beep signal), this indicates that the new heel height could not be stored. Repeat the heel height measurement.

9.2 Movement patterns in basic mode (mode 1)

9.2.1 Standing

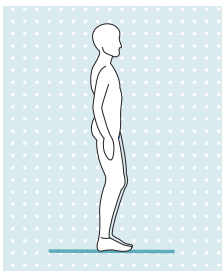

The intuitive stance function recognises any situation where the prosthesis is kept still while standing. The standing position is stabilised through high dorsiflexion damping with vertical lower leg. Plantar flexion is damped only slightly, so that the lower leg can be pulled back into the neutral position to correct the standing position.

This function is deactivated during rollover to the front or by lifting the prosthesis off the floor.

Coming to a stop with the prosthesis side after walking can lead to the knee joint sinking in as a result of the ankle position during the rollover. To restore a stable standing position, place the leg back under the body and stretch the leg or put weight on the heel.

The relief function can be used when standing (see Page 27).

9.2.2 Walking

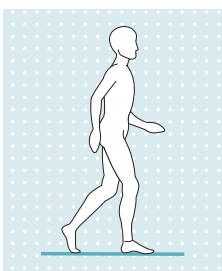

Initial attempts at walking with the prosthetic foot always require instruction by trained, qualified personnel.

When walking, the damping of the dorsiflexion and plantar flexion is adapted to the current walking phase, making a physiological gait possible.

Plantar flexion damping is increased during heel strike in order to provide support for stance phase flexion in the knee.

By increasing dorsiflexion damping in the stance phase, the lower leg is led into an extended rollover angle. The rollover behaviour automatically adjusts itself to the walking speed.

Plantar flexion damping is increased during the transition to the swing phase in order to prevent the toes from dropping and to maintain ground clearance.

During the swing phase, plantar flexion damping is adjusted to the current position of the lower leg at all times. This ensures a comfortable tread, with suitable heel leverage for the respective step length.

9.2.3 Sitting down/sitting

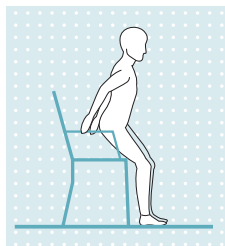

Sitting down

- 1) Place both feet side by side at the same level.
- 2) While sitting down, distribute weight evenly between both legs and use armrests, if available.
- 3) Move the buttocks in the direction of the backrest and lean the upper body forward.

Sitting

The relief function can be used when sitting; the tip of the foot lowers to reach a more natural foot position. (see Page 27).

9.2.4 Standing up

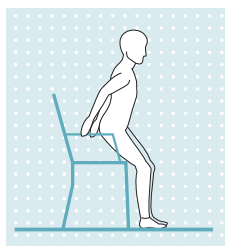

- 1) Place the feet at the same level. Make sure the foot is positioned perpendicularly under the knee or shifted further forward, and that weight is distributed evenly over the feet.

INFORMATION: The ankle joint may lock if the prosthetic foot is set further back than at a perpendicular angle under the knee.

- 2) Lean the upper body forward.
- 3) Put the hands on armrests, if available.
- 4) Stand up with support from the hands, while keeping weight evenly distributed on the feet.

9.2.5 Walking up stairs

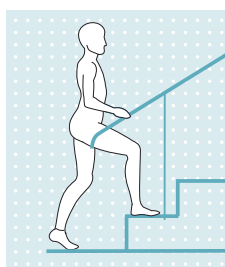

The position is stabilised through high dorsiflexion damping with vertical lower leg. Walking up stairs step-over-step is possible, depending upon the type of fitting.

Always hold on to the handrail with one hand when walking up steps.

9.2.6 Walking down stairs

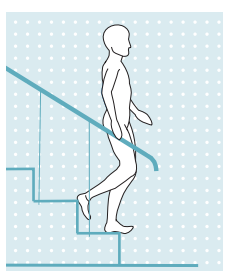

This function must be practised and executed consciously. Only by properly stepping down with the sole can the system switch correctly and permit controlled rollover. The motion must be carried out in a continuous pattern in order to allow the motion to proceed in a fluid manner.

A stair function can be activated by using the adjustment software. See the following section for further information regarding the stair function.

- 1) Hold on to the handrail with one hand.
- 2) Position the leg with the prosthetic foot on the step so that as much of the sole of the foot as possible is on the step.

INFORMATION: Rolling the foot over the edge of the stair is not necessary.

- 3) Place the contralateral side onto the next step.
While doing so, check whether the knee joint and prosthetic foot will allow this motion.
- 4) Place the leg with the prosthetic foot on one step beyond the next step.
- 5) At the end of the stairs, take a bigger step when transitioning to level ground, so that the prosthetic foot switches over correctly from walking down the stairs to normal walking phase.

9.2.6.1 Stair function

The stair function increases the rollover angle when walking down stairs. This function should be switched on when walking down stairs step-over-step. If walking down stairs step-over-step is not required, this function can be switched off. Further information on switching on/off see Page 30.

9.2.7 Walking up a ramp

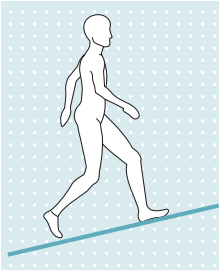

With the first step, the foot is already adjusted to the inclination of the ramp, making a rollover possible if the step is on the heel or middle of the foot. In order to do so, the lower leg should be positioned almost perpendicular to the surface of the ramp and the full area of the foot should be placed on the surface.

When stepping on the forefoot with the lower leg at a steep angle (e.g. on very steep ramps), the foot secures dorsiflexion, which enables the body to be lifted in a stable manner.

9.2.8 Walking down a ramp

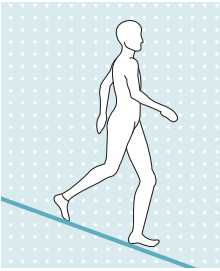

With the first step, the foot is already adjusted to the inclination of the ramp, making it possible for the heel to strike with extended plantar flexion so the complete area of the foot is on the surface during the rollover.

After the foot is put down on the ramp, you should not use the knee to work against it, but should allow flexion in the knee joint for the heel strike (yielding). Only in this way will the foot be able to recognise the motion as walking and allow an extended rollover. This allows for a guided lowering of the body's centre of gravity.

Plantar flexion is limited for walking with a prosthetic knee joint (higher amputation level than transtibial amputation) in order to support flexion in the knee joint during heel strike (yielding).

9.2.9 Walking backwards

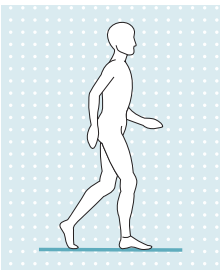

When the toe is put down first while walking backwards, the ankle joint only drops as far as the neutral position in the dorsiflexion direction. As a result, the preceding rollover motion is balanced out and the user can stand safely.

9.2.10 Standing on inclined surface

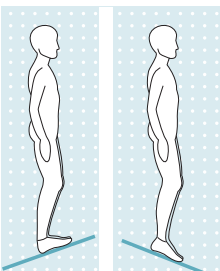

Standing on an inclined ground surface is no different to standing on a level surface. The foot stabilises in dorsiflexion when the lower leg is perpendicular. Put weight on the heel in order to lower the forefoot (e.g. when standing in a downward direction).

Perform one of the following motions in order to continue to walk on a downward-sloping ground surface from the standing position:

- Start the first step with the prosthesis side.
- Deliberately produce a rollover motion with the prosthesis side.

The prosthetic foot then yields in dorsiflexion, in order to allow the body's centre of gravity to drop before the heel of the other leg strikes.

The relief function can be used when standing on an inclined surface (see Page 27).

Wearing shoes with heels limits the range of incline, so it may not be possible to achieve a perpendicular lower leg.

9.2.11 Kneeling

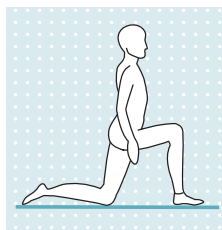

If the leg with the joint is tilted backwards, plantar flexion damping is reduced, making it possible for the foot to bend so the lower leg can lie flatter to the ground surface.

9.2.12 Relief function

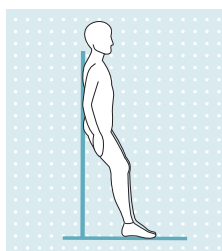

When weight is consistently placed on the heel without movement for more than 2 seconds, the tip of the foot lowers to reach a more natural foot position. In comparison to a prosthetic foot that cannot be adjusted automatically, this results in a more even distribution of pressure between the residual limb and the socket.

Possible applications include sitting with the heel in front of the knee axis, standing while leaning against something, and standing on a downward sloping surface.

9.3 MyModes

The adjustment software can be used to activate and configure MyModes in addition to the basic mode. These can be called up by the patient using the remote control or motion patterns. Switching by using motion patterns has to be activated in the adjustment software.

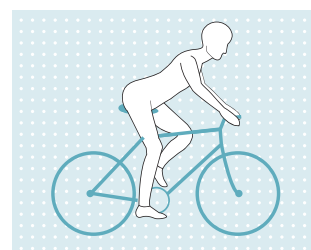
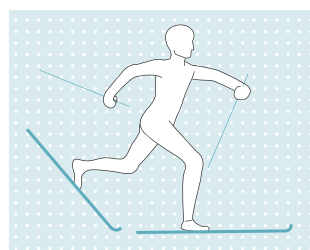
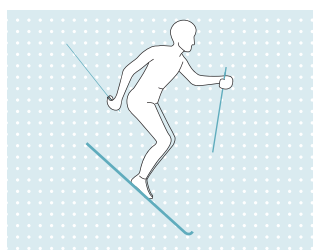
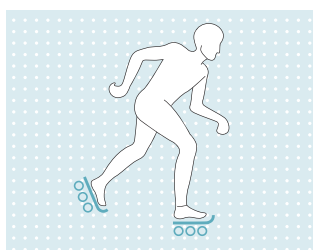

These modes are intended for specific motion patterns or postures (e.g. inline skating, ...). Default settings for these motion patterns and postures can be called up and individually adapted using the adjustment software.

Settings can also be adjusted by the patient using the cockpit app or remote control (see Page 31).

9.3.1 Switching MyModes with the cockpit app

INFORMATION

Bluetooth on the prosthesis must be turned on in order to use the cockpit app.

If Bluetooth is switched off, it can be turned on by turning the prosthesis upside-down or by connecting/disconnecting the battery charger. Bluetooth is then turned on for approx. 2 minutes. During this time, the app must be started and used to establish a connection. If required, Bluetooth on the prosthesis can be switched on permanently afterwards (see Page 32).

INFORMATION

If the **VOLUME** parameter is set to '0' in the Cockpit app or using the remote control, there are no beep signals (see Page 29).

Once a connection to a prosthesis has been established, the cockpit app can be used to switch between the MyModes.

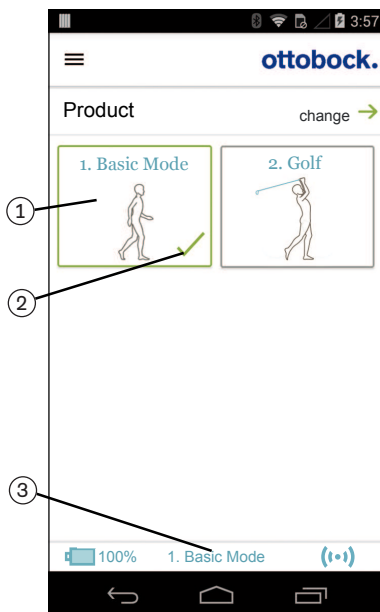

- 1) Tap the symbol of the MyMode (1) you want in the main menu of the app.
→ A security question for changing the MyMode appears.
- 2) If you want to change the mode, tap the "OK" button.
→ A beep signal sounds to confirm the switch.
- 3) After switching, a symbol (2) is displayed to identify the active mode.
→ The current mode is also indicated by the name on the lower edge of the screen (3).

9.3.2 Switching MyModes using motion patterns

INFORMATION

If the **VOLUME** parameter is set to '0' in the Cockpit app or using the remote control, there are no beep signals (see Page 29).

Information on switching

- Switching and the number of motion patterns must be activated in the adjustment software.
- Before further activities, always check whether the selected mode corresponds to the required motion type.

Switching process

- 1) Hold the prosthetic leg under the body.
- 2) Using the heel of the prosthetic foot, knock on a solid obstacle behind you (e.g. a wall) according to the number of the configured MyMode (MyMode 1 = 3 times, MyMode 2 = 4 times, MyMode 3 = 5 times). It is also possible to knock against the tip of the shoe of the contralateral leg.
→ A beep and vibration signal will occur to confirm that the movement pattern has been recognised.
INFORMATION: If this beep and vibration signal is not emitted, the requirements were not met while bouncing.
- 3) Lean the prosthetic foot slightly to the back and place weight on the forefoot.
INFORMATION: If the prosthetic foot is strongly dorsiflexed, weight can be placed on the heel.
→ A confirmation signal will sound to indicate that the prosthesis has successfully switched to the corresponding mode (2 times = MyMode 1, 3 times = MyMode 2, 4 times = MyMode 3).
INFORMATION: If this confirmation signal does not occur, weight was not placed on the prosthetic foot correctly or not for enough time. Repeat the process to correctly switch to the required mode.
- 4) Remove the load from the prosthetic leg.
→ The mode has been changed.

9.3.3 Switching on ankle lock

INFORMATION

If the **VOLUME** parameter is set to '0' in the Cockpit app or using the remote control, there are no beep signals (see Page 29).

Information on switching

- The ankle lock must be activated as MyMode "Ankle lock" and the number of motion patterns used to switch it on must be activated in the adjustment software.
- Before further activities, always check whether the selected mode corresponds to the required motion type.

Switching process

- 1) Hold the prosthetic leg under the body.
- 2) Using the heel of the prosthetic foot, knock on a solid obstacle behind you (e.g. a wall) according to the number of the configured MyMode (MyMode 1 = 3 times, MyMode 2 = 4 times, MyMode 3 = 5 times). It is also possible to knock against the tip of the shoe of the contralateral leg.
 - A beep and vibration signal will occur to confirm that the movement pattern has been recognised.
- 3) Lean the prosthetic foot slightly to the back and place weight on the forefoot.

INFORMATION: If the prosthetic foot is strongly dorsiflexed, weight can be placed on the heel.

 - A confirmation signal will sound to indicate that the prosthesis has successfully switched to the corresponding mode (2 times = MyMode 1, 3 times = MyMode 2, 4 times = MyMode 3).
 - INFORMATION: If this confirmation signal does not occur, weight was not placed on the prosthetic foot correctly or not for enough time. Repeat the process to correctly switch to the required mode.**
- 4) Remove the load from the prosthetic leg.
 - The mode has been changed.
- 5) Within 2 seconds, lower the prosthetic leg and assume the required position of the ankle angle.
 - At the end of this time, a signal will occur to indicate the locking of the ankle joint.

9.3.4 Switching from a MyMode back to basic mode

INFORMATION

If the **VOLUME** parameter is set to '0' in the Cockpit app or using the remote control, there are no beep signals (see Page 29).

Information on switching

- Regardless of the configuration of additional MyModes in the adjustment software, it is always possible to switch back to basic mode (mode 1) with a motion pattern.
- It is always possible to switch back to basic mode (mode 1) by connecting/disconnecting the battery charger.
- Before further activities, always check whether the selected mode corresponds to the required motion type.

Switching process

- 1) Hold the prosthetic leg under the body.
 - 2) Using the heel of the prosthetic foot, knock on a solid obstacle behind you at least 3 times but no more than 5 times.
 - A beep and vibration signal will occur to confirm that the motion pattern has been recognised.
 - 3) Lean the prosthetic foot slightly to the back and place weight on the forefoot.

INFORMATION: If the prosthetic foot is strongly dorsiflexed, weight can be placed on the heel.

 - A confirmation signal will sound to indicate that the prosthesis has successfully switched over to basic mode.
 - INFORMATION: If this confirmation signal does not occur, weight was not placed on the prosthetic foot correctly or not for enough time. Repeat the process to correctly switch to the required mode.**
 - 4) Remove the load from the prosthetic leg.
 - The mode has been changed.
- Before further activities, always check whether the selected mode corresponds to the required motion type.

9.4 Changing prosthesis settings

Information for changing the prosthesis settings



Once an active connection to a prosthesis has been established, the settings of the **mode currently active** can be changed using the cockpit app or the remote control (optional accessory).

INFORMATION

Bluetooth on the prosthesis must be switched on to change the prosthesis settings.

If Bluetooth is switched off, it can be turned on by turning the prosthesis upside-down or by connecting/disconnecting the battery charger. Bluetooth is then turned on for approx. 2 minutes. The connection must be established during this period.

- Before changing settings, always check the main menu of the cockpit app or the display of the remote control (optional accessory) to make sure the correct prosthesis has been selected. Otherwise, parameters could be changed for the wrong prosthesis.

- It is not possible to change prosthesis settings nor to switch to a different mode while the prosthesis battery is being charged. Only the status of the prosthesis can be called up. Instead of the  symbol, the  symbol appears in the bottom row of the screen in the cockpit app.
- The prosthetist's setting is located in the middle of the scale. After making adjustments, this setting can be restored by tapping the "Standard" button (Cockpit app) or by moving the slider control into the middle (remote control).
- Prosthesis settings should be optimised using the adjustment software. The cockpit app or remote control (optional accessory) is not intended for use by the prosthetist in order to set up the prosthesis. The day-to-day behaviour of the prosthesis can be changed to a certain degree by the patient with the remote control or app (e.g. as they become accustomed to the prosthesis). The prosthetist can use the adjustment software to trace these changes at the patient's next appointment.
- If the settings of a MyMode are to be modified, one must first switch to this MyMode.

9.4.1 Changing the prosthesis setting using the cockpit app

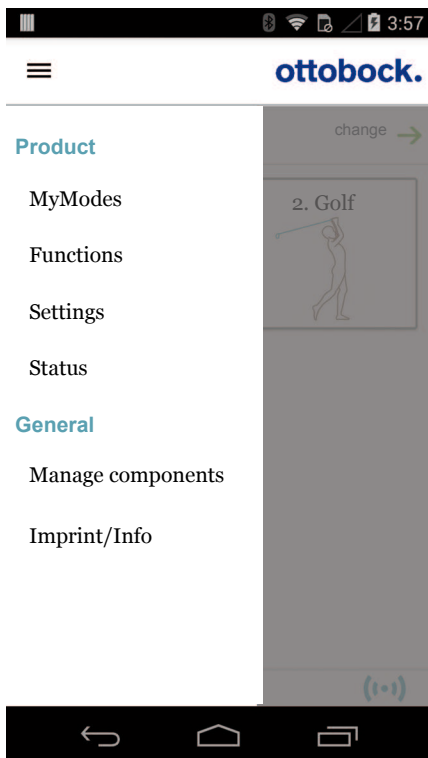

- 1) Once the component is connected and in the desired mode, tap the  symbol in the main menu.
→ The navigation menu opens.
- 2) Tap the menu entry "Settings".
→ A list appears with the parameters for the currently selected mode.
- 3) Change the setting of the desired parameter by tapping the "<", ">" symbols.
INFORMATION: The prosthetist's setting is marked and, after the setting has been changed, can be restored by tapping the "Standard" button.

9.4.2 Overview of adjustment parameters in basic mode

The parameters in basic mode describe the dynamic behaviour of the prosthesis in a normal gait cycle. These parameters act as basic settings for automatically adjusting the damping behaviour to the current motion situation (e.g. ramps, slow walking speed, etc.).

The following parameters can be modified:

Remote control parameter	Adjustment software range	App/remote control adjustment range	Meaning
PITCH	1000 Hz – 4000 Hz	1000 Hz – 4000 Hz	Pitch (frequency) of beep signal for acknowledgement tones
VOLUME	0 – 4	0 – 4	Volume of beep signal for confirmation tones (e.g. when checking the charge level, switching MyModes). The "0" setting deactivates the audible feedback signals. However, warning signals in case of errors are still generated (see Page 37).
HEEL RESIST.	10 – 60	± 20	

Remote control parameter	Adjustment software range	App/remote control adjustment range	Meaning
			Plantar flexion damping. How fast the forefoot is lowered when weight is placed on the heel.
ROLLOVER RESIST.	110 – 170	± 10	This parameter defines how easy the rollover is.
STAIR FUNCTION	ON – OFF	ON – OFF	Switching on this function increases the rollover angle when walking down stairs. This function needs to be enabled in the adjustment software.

9.4.3 Overview of adjustment parameters in MyModes

The parameters in the MyModes describe the static behaviour of the prosthesis for a specific motion pattern such as golf. Damping behaviour is not automatically controlled and adjusted in MyModes.

The following parameters can be modified in MyModes:

Parameter	Adjustment software range	App/remote control adjustment range	Meaning
HEEL RESIST.	0 – 195	± 20	Plantar flexion damping. How fast the forefoot lowers itself during heel load.
ROLLOVER RESIST.	0 – 195	± 10	Dorsiflexion damping. How easily the value of the "STOP ANGLE" parameter can be reached, in other words how strong the resistance is to reaching the value of the "STOP ANGLE" parameter.
STOP ANGLE	-200 – 200	± 10 displayed in 0.1°	Ankle angle from which motion in the rollover direction (in direction of dorsiflexion) is locked.

9.5 Switching off the product

⚠ CAUTION

Using the product while switched off

Falling due to unexpected behaviour of the product because of changed damping behaviour.

- ▶ Before using the product, switch it on by connecting the power supply and battery charger.

If the prosthesis is not being worn, it switches to energy saving mode after some time (15 minutes). All sensors are turned off. Energy saving mode is deactivated again as soon as the prosthesis is moved.

In certain cases, e.g. for storage or transportation, the prosthesis can be purposely switched off. It can only be switched on by connecting to a live outlet, a power supply and a battery charger.

Switching off

- ▶ Connect/disconnect the battery charger to/from the product 3x. A wait time less than 3 seconds is required before disconnecting the battery charger again.
- After disconnecting 3 times, a descending sequence of 5 beeps is emitted and the product is then switched off.

Switching on

- 1) Connect the power supply with battery charger to the socket.
- 2) Connect the battery charger to the product.
 - The correct connection of the battery charger to the product is indicated by feedback (see Page 36 and see Page 39).

9.6 Turning Bluetooth on the prosthesis on/off

INFORMATION

Bluetooth on the prosthesis must be turned on in order to use the cockpit app. If Bluetooth is switched off, it can be turned on by turning the prosthesis upside-down or by connecting/disconnecting the battery charger. Bluetooth is then turned on for approx. 2 minutes. During this time, the app must be started and used to establish a connection. If required, Bluetooth on the prosthesis can be switched on permanently afterwards (see Page 32).

9.6.1 Switching Bluetooth off/on using the cockpit app

Switching off Bluetooth

- 1) When the component is connected, tap the ☰ symbol in the main menu.
→ The navigation menu opens.
- 2) In the navigation menu, tap the entry "**Functions**".
- 3) Tap the entry "**Deactivate Bluetooth**".
- 4) Follow the on-screen instructions.

Switching on Bluetooth

- 1) Rotate the component or connect/disconnect the battery charger.
→ Bluetooth is switched on for approx. 2 minutes. During this time, the app must be started in order to establish a connection to the component.
- 2) Follow the on-screen instructions.
→ If Bluetooth is switched on, the (•••) symbol appears on the screen.

9.7 Querying the prosthesis status

9.7.1 Query status through cockpit app

- 1) When the component is connected, tap the ☰ symbol in the main menu.
- 2) In the navigation menu, tap the entry "**Status**".

9.7.2 Status display in the cockpit app

Menu option	Description	Possible actions
TRIP: 1747	Daily step counter	Reset the counter by tapping the " Reset " button.
STEP: 1747	Total step counter	For informational purposes only
BATT.: 68	Current prosthesis charge level, as a percentage	For informational purposes only

9.7.3 Status information on the display of the remote control (optional accessory)

Menu option	Description	Possible actions
TRIP:1747	Daily step counter	Reset the counter by using the ■ key to confirm the menu option
STEP:1747	Total step counter	For informational purposes only
BATT.:68	Current prosthesis charge level, as a percentage	For informational purposes only
BLUETOOTH: ON	Switch Bluetooth function of the prosthesis on or off	The Bluetooth function of the prosthesis can be turned on or off (see Page 32) by confirming the menu item with the ■ key.

10 Additional operating states (modes)

10.1 Empty battery mode

Beeps and vibration signals are emitted if the available battery charge level drops to 0% (see Page 37). During this time, damping settings are set to their safety mode values. The prosthesis is then switched off. You can switch back to basic mode (mode 1) from empty battery mode by charging the product.

10.2 Mode for charging the prosthesis

The ankle joint of the prosthetic foot is locked during the charging process.

10.3 Safety mode

The product automatically switches to safety mode if a critical system error occurs (e.g. failure of a sensor signal) or when the battery is empty. Safety mode remains in effect until the error has been rectified.

Default damping values are activated in safety mode. This makes limited walking possible for the user even though the system is not active.

The switch to safety mode is indicated by beeps and vibration signals immediately prior to switching (see Page 37).

Safety mode can be disabled by connecting then disconnecting the battery charger. If the product switches into safety mode again, this means a permanent error exists. The product must be inspected by an authorised Ottobock Service Centre.

10.4 Overheating mode

When the hydraulic unit overheats due to uninterrupted, increased activity (e.g. extended walking downhill), damping is increased along with the rising temperature in order to counteract the overheating. When the hydraulic unit cools down, the product switches back to the damping settings that existed before the overheating mode.

Overheating mode is indicated by a brief vibration every 5 seconds.

11 Cleaning

- 1) Clean the product with a damp cloth and mild soap (e.g. Ottobock 453H10=1 Derma Clean) when needed. Ensure that no liquid penetrates into the system component(s).
- 2) Dry the product with a lint-free cloth and allow it to air dry fully.

12 Maintenance

INFORMATION

The foot shell for the prosthetic foot has an expected working life of approx. one year when professionally mounted and properly used. Damaged foot shells must be replaced immediately, before the prosthetic foot is used again.

Regular service inspections are recommended in the interest of the patient's safety and in order to maintain operating reliability and protect the warranty. These service inspections include an inspection of sensors and replacement of worn parts.

To have a service inspection carried out, please send the product as well as the battery charger and power supply unit to an authorised Ottobock Service Centre.

INFORMATION

If a remote control was included in the scope of delivery as an optional product accessory, it must also be sent along with the product for service inspections.

13 Disposal



This product may not be disposed of with regular domestic waste in all jurisdictions. Disposal that does not comply with the regulations of your country may have a detrimental impact on health and the environment. Please observe the information provided by the responsible authorities in your country regarding return and collection processes.

14 Legal information

All legal conditions are subject to the respective national laws of the country of use and may vary accordingly.

14.1 Liability

The manufacturer will only assume liability if the product is used in accordance with the descriptions and instructions provided in this document. The manufacturer will not assume liability for damage caused by disregard of this document, particularly due to improper use or unauthorised modification of the product.

14.2 Trademarks

All product names mentioned in this document are subject without restriction to the respective applicable trademark laws and are the property of the respective owners.

All brands, trade names or company names may be registered trademarks and are the property of the respective owners.

Should trademarks used in this document fail to be explicitly identified as such, this does not justify the conclusion that the denotation in question is free of third-party rights.

14.3 CE Conformity

This product meets the requirements of the European Directive 93/42/EEC for medical devices. This product has been classified as a class I device according to the classification criteria outlined in Annex IX of the directive. The declaration of conformity was therefore created by the manufacturer with sole responsibility according to Annex VII of the directive.

This product meets the requirements of the European Directive 1999/5/EC for radio equipment and telecommunications terminal equipment. The conformity assessment was drawn up by the manufacturer in accordance with Annex III of the directive.

14.4 Local Legal Information

Legal information that applies **exclusively** to specific countries is written in the official language of the respective country of use in this chapter.



This device complies with part 15 of the FCC Rules. Operation is subject to the following two conditions:

- 1) This device may not cause harmful interference, and
- 2) This device must accept any interference received, including interference that may cause undesired operation.

This equipment has been tested and found to comply with the limits for a Class B digital device, pursuant to part 15 of the FCC Rules. These limits are designed to provide reasonable protection against harmful interference in a residential installation. This equipment generates uses and can radiate radio frequency energy and, if not installed and used in accordance with the instructions, may cause harmful interference to radio communications. However, there is no guarantee that interference will not occur in a particular installation. If this equipment does cause harmful interference to radio or television reception, which can be determined by turning the equipment off and on, the user is encouraged to try to correct the interference by one or more of the following measures:

- Reorient or relocate the receiving antenna.
- Increase the separation between the equipment and receiver.
- Connect the equipment into an outlet on a circuit different from that to which the receiver is connected.
- Consult the dealer or an experienced radio/ TV technician for help.

Any changes or modifications not expressly approved by the party responsible for compliance could void the user's authority to operate the equipment.

Caution: Exposure to Radio Frequency Radiation.

This device must not be co-located or operating in conjunction with any other antenna or transmitter.

Responsible party:

Otto Bock Health Care, LP
3820 West Great Lakes Drive
Salt Lake City, Utah 84120-7205 USA
Phone + 1-801-956-2400
Fax + 1-801-956-2401

This device complies with RSS 210 of Industry Canada.

Operation is subject to the following two conditions:

- (1) this device may not cause interference, and
- (2) this device must accept any interference, including interference that may cause undesired operation of this device.

L' utilisation de ce dispositif est autorisée seulement aux conditions suivantes:

- (1) il ne doit pas produire d'interférence et

(2) l' utilisateur du dispositif doit être prêt à accepter toute interference radioélectrique reçue, même si celle-ci est susceptible de compromettre le fonctionnement du dispositif.

Caution: Exposure to Radio Frequency Radiation.

The installer of this radio equipment must ensure that the antenna is located or pointed such that it does not emit RF field in excess of Health Canada limits for the general population; consult Safety Code 6, obtainable from Health Canada's website

<http://www.hc-sc.gc.ca/rpb>.

Responsible party:

Otto Bock Healthcare Canada Ltd.

5470 Harvester Road

L7L 5N5 Burlington, Ontario

Canada









Phone + 1-800-665-3327

Caution: Federal law (USA) restricts this device to sale by or on the order of a practitioner licensed by law of the State in which he/she practices to use or order the use of the device.

15 Appendices

15.1 Symbols Used

15.1.1 Symbols on the product

-  Legal manufacturer
-  Compliance with the requirements according to "FCC Part 15" (USA)
-  Compliance with the requirements according to the "Radiocommunications Act" (AUS)
-  Non-ionising radiation
-  In some jurisdictions it is not permissible to dispose of these products with unsorted household waste. Disposal that is not in accordance with the regulations of your country may have a detrimental impact on health and the environment. Please observe the instructions of your national authority pertaining to return and collection.
-  Declaration of conformity according to the applicable European directives
-  SN|YYYY WW NNN Serial number
-  IP54 Protected against dust, protected against splashing water

15.1.2 Symbols on remote control

 Legal manufacturer

 LOT|PPPP YYYY WW Lot number



In some jurisdictions it is not permissible to dispose of these products with unsorted household waste. Disposal that is not in accordance with the regulations of your country may have a detrimental impact on health and the environment. Please observe the instructions of your national authority pertaining to return and collection.



Declaration of conformity according to the applicable European directives



Non-ionising radiation



Compliance with the requirements according to "FCC Part 15" (USA)



Compliance with the requirements according to the "Radiocommunications Act" (AUS)

15.1.3 Symbols on the battery charger



Declaration of conformity according to the applicable European directives



In some jurisdictions it is not permissible to dispose of these products with unsorted household waste. Disposal that is not in accordance with the regulations of your country may have a detrimental impact on health and the environment. Please observe the instructions of your national authority pertaining to return and collection.

LOT:PPPP YYYY WW Lot number

15.2 Operating states/error signals

The prosthesis indicates operating states and error messages through beeps and vibration signals.

15.2.1 Signals for operating states

Battery charger connected/disconnected

Beep signal	Vibration signal	Event
1x short		Battery charger is connected or battery charger already disconnected prior to start of charging mode
	3x short	Charging mode started (3 sec. after connection of battery charger)
1x short	1x before beep signal	Battery charger disconnected after start of charging mode

Mode switching

INFORMATION

If the **VOLUME** parameter is set to '0' in the Cockpit app or using the remote control, there are no beep signals (see Page 29).

Beep signal	Vibration signal	Additional action performed	Event
1x short	1x short	Mode switching using remote control	Mode switching performed using remote control
1x short	1x short	Knocking with heel to switch modes or	Movement pattern recognised

Beep signal	Vibration signal	Additional action performed	Event
		swing sideways 3 x to set heel height	
1x short	1x short	Weight placed on prosthetic leg and leg kept still for 1 second to switch mode or feet placed on same level and weight distributed evenly on both feet to set heel height	Switching to basic mode (mode 1) carried out.
2x short	2x short	Weight placed on prosthetic leg and leg kept still for 1 second	Switching to MyMode 1 (mode 2) carried out.
3x short	3x short	Weight placed on prosthetic leg and leg kept still for 1 second	Switching to MyMode 2 (mode 3) carried out.

15.2.2 Warnings/error signals

Error during use

Beep signal	Vibration signal	Event
	3x long	Battery charge level under 25%
	5x long	Battery charge level under 15%
10x long	10x long	Battery charge level at 0%:

Beep signal	Vibration signal	Event	Required action
	1 x short at interval of approx. 5 seconds	Overheated hydraulic unit	Reduce activity
10 x short	10 x long	Battery charge level at 0% Switch to safety mode.	Charge battery
30 x long	Intermittent for 5 minutes	Severe error e.g. failure of valve drives Possibly no switching into safety mode.	Restricted walking possible. Attempt to reset this error by connecting/disconnecting the battery charger. If the error persists, it is no longer permissible to use the product. The product must be inspected by an authorised Ottobock Service Centre.

Error while charging the product

LED on power supply	LED on battery charger	Error	Resolution
○	🔌 ○ ○ ⓘ	Country-specific plug adapter not fully engaged on power supply	Check whether the country-specific plug adapter is fully engaged on the power supply.
		Non-functional socket	Check socket with another electric device.
		Defective power supply	The battery charger and power supply must be inspected by an authorised Ottobock Service Centre.
●	🔌 ○ ○ ⓘ	No connection between battery charger and power supply	Check whether the charging cable plug is fully engaged on the battery charger.
		Defective battery charger	The battery charger and power supply must be inspected by an authorised Ottobock Service Centre.

LED on power supply	LED on battery charger	Error	Resolution
●	🔋 ○ ● Ⓜ	Battery is fully charged (or connection with product is interrupted).	<p>Take note of the confirmation signal for differentiation.</p> <p>When the battery charger is connected or disconnected, a self-test is conducted and confirmed by a beep and vibration signal. The battery is fully charged if this signal is heard.</p> <p>If no signal is emitted, the connection to the product is interrupted.</p> <p>If the connection to the product is interrupted, an authorised Ottobock Service Centre must inspect the product, battery charger and power supply.</p>

Beep signal	Error	Resolution
4 x short at intervals of approx. 20 sec. (continuously)	Charging the battery outside the allowable temperature range	Check whether the specified ambient conditions for charging the battery are met (see Page 39).

Error after disconnecting the battery charger (error on self-test)

Beep signal	Vibration signal	Error	Resolution
3x short		Minor error: e.g. service interval has been exceeded, disruption of a sensor signal	Contact Ottobock



15.2.3 Error messages while establishing a connection

Error message	Cause	Remedy
DEVICE NOT FOUND	A previously saved connection to the prosthesis could not be established.	<p>Check the following points:</p> <ul style="list-style-type: none"> • Distance from the prosthesis to the remote control • Battery charge level of the prosthesis • Active connection with the adjustment software? • Bluetooth on the prosthesis switched on? (see Page 32) • Prosthesis switched on? (see Page 31) • If multiple prostheses were stored in the remote control unit, was the correct prosthesis selected? <ol style="list-style-type: none"> 1) Connect the battery charger to the prosthesis, then charge the battery for at least 3 hours. You can try to establish connection again while the battery is charging. 2) Use the ■ key to confirm the error message and try to establish the connection again. 3) See section "Managing prostheses" (Managing prostheses) for further information.
DEVICE DISCONNECTED	A current connection to the prosthesis was interrupted	Check the following points:

Error message	Cause	Remedy
		<ul style="list-style-type: none"> Distance from the prosthesis to the remote control Was the prosthesis connected to another remote control? The connection that was already saved in the remote control must be deleted in order to re-connect the prosthesis to this remote control. A new connection must then be established from the prosthesis to this remote control (Managing prostheses). Use the ■ key to confirm the error message and try to establish the connection again.
NO NEW DEVICE FOUND	No new prosthesis could be found since this prosthesis is already stored.	<ol style="list-style-type: none"> 1) Confirm error message with the ■ key. 2) Use the ▲, ▼ keys to select the menu option "SELECT DEVICE" and confirm this with the ■ key. 3) Use the ▲, ▼ keys to select the prosthesis required and confirm this with the ■ key.

15.2.4 Status signals



Battery charger is connected

LED on power supply	LED on battery charger	Event
		Power supply and battery charger operational

Battery charger disconnected

Beep signal	Vibration signal	Event
1x short	1x short	Self-test completed successfully. Product is operational.

Battery charge level

Battery charger	
	Battery is being charged, battery charge level is less than 50%
	Battery is being charged, battery charge level is over 50%
	<p>Battery is fully charged (or connection with product is interrupted). Take note of the confirmation signal for differentiation. When the battery charger is connected or disconnected, a self-test is conducted and confirmed by a beep and vibration signal. The battery is fully charged if this signal is heard. If no signal is emitted, the connection to the product is interrupted.</p>

15.3 Technical data

Environmental conditions	
Storage and transport in original packaging (≤3 months)	-20 °C/-4 °F to +40 °C/+104 °F
Storage and transport without packaging (<48 hours)	-25 °C/-13 °F to +70 °C/+122 °F Max. 93% relative humidity, non-condensing
Long-term storage (>3 months)	-20°C/-4°F to +20°C/+68°F Max. 93% relative humidity, non-condensing
Operation	-10°C/+14°F to +40°C/+104°F Max. 93% relative humidity, non-condensing

Environmental conditions						
Charging the battery	+10 °C/+50 °F to +45 °C/+113 °F					
Product						
Reference number	1B1					
Maximum heel height that can be set	50 mm/2 inch					
Dorsiflexion with heel height of 1 cm/0.39 inches	14.5°					
Plantar flexion with heel height of 1 cm/0.39 inch	22°					
Mobility grade according to MOBIS	2 - 4					
Footshell colours	Translucent, beige, brown					
Max. system height with heel height of 2 cm/0.79 inch	18.5 cm/7.28 inch					
Protection rating	IP54					
Range of Bluetooth connection to PC	max. 10 m/32 ft					
Range of Bluetooth connection to remote control	max. 10 m/32 ft					
Foot size [cm]	24	25	26	27	28	29
Max. body weight	100 kg/220 lbs		100 kg/220 lbs		100 kg/220 lbs	
Max. weight incl. footshell	approx. 1250 g/44 oz		approx. 1500 g/53 oz		approx. 1550 g/55 oz	
Prosthesis battery						
Battery type	Li-Ion					
Charging cycles (charging and discharging cycles) after which at least 80% of the original battery capacity remains available	500					
Charging time until battery is fully charged	8 hours					
Behaviour of prosthetic foot while being charged	The ankle joint of the prosthetic foot is locked					
Operating time of prosthesis with fully charged battery	1 day with average use					
Remote control						
Reference number	4X350					
Charging cycles (charging and discharging cycles) after which at least 80% of the original battery capacity remain available.	300					
Battery type	Li-Ion					
Charging time until battery is fully charged	4 hours					
Behaviour of remote control unit while being charged	<ul style="list-style-type: none"> When the remote control unit is switched off, the current charge level of the battery is shown on the display. When the remote control unit is switched on, the current charge level of the battery is also shown in place of the start-up screen. Remote control unit functional without restriction. 					
Operating time with fully charged battery	approx. 2 months with average use					
Battery charger						
Reference number	4E50*					
Storage and transport in original packaging	-25 °C/-13 °F to +70 °C/+158 °F					
Storage and transport without packaging	-25 °C/-13 °F to +70 °C/+158 °F max. 93 % relative humidity, non-condensing					
Operation	0 °C/+32 °F to +40 °C/+104 °F max. 93 % relative humidity, non-condensing					
Input voltage	12 V $\overline{=}$					

The product 1B1 is covered by the following patents:

Australia:	AU 2005 256 306
Canada:	CA 2 570 459
China:	CN 1 984 622; CN 101 569 567; CN 101 569 568
Finland	FI 110 159
Germany	DE 10 2008 008 282
Japan:	JP 4 392 039, JP 5 237 144; JP 5 575 409
Russia:	RU 2 352 297, RU 2 473 322, RU 2 473 323
South Korea	KR 101 190 416
USA:	US 8 246 695; US 6 908 488; US 8 295 294; US 8 828 095; US 8 728 171
European Patent	EP 1237513 in DE, FR, GB EP 1761219 in CZ, DE, FR, GB, IT, NL, NO, PL, SE, TR EP 2087859 in CZ, DE, FR, GB, IT, NL, PL, SE, TR EP 2417940 in DE, FR, GB, IT, NL, SE, TR EP 2493427 in DE, FR, GB, IT, NL, SE, TR

Patents pending in Australia, Brazil, Canada, China, EPA, Germany and USA.



Otto Bock Healthcare Products GmbH
Brehmstraße 16 · 1110 Wien · Austria
T +43-1 523 37 86 · F +43-1 523 22 64
info.austria@ottobock.com · www.ottobock.com

Ottobock has a certified Quality Management System in accordance with ISO 13485.